



OWNER'S MANUAL

Thank you for purchasing this ecox product.
Before using this machine, please read this manual and retain it for future reference.

EDES



ecox DEHUMIDIFIER

EDES

Register your product at
www.ecoxline.com
ecoxline
f t i YouTube



CONTENT

- 4** SAFETY PRECAUTIONS
- 6** CONTROL PADS ON THE DEHUMIDIFIER
- 8** IDENTIFICATION OF PARTS
- 9** OPERATING THE UNIT
- 10** CARE AND MAINTENANCE
- 11** TROUBLESHOOTING TIPS



CAUTION

- *This appliance can be used by children aged from 8 years and above and persons with reduced physical, sensory or mental capabilities or lack of experience and knowledge if they have been given supervision or instruction concerning use of the appliance in a safe way and understand the hazards involved. Children shall not play the appliance. Cleaning and user maintenance shall not be made by children without supervision.*
- *This appliance is not intended for use by persons (including children) with reduced physical, sensory or mental capabilities or lack of experience and knowledge, unless they have been given supervision or instruction concerning use of the appliance by a person responsible for their safety.*
- *Children should be supervised to ensure that they do not play with the appliance.*
- *If the supply cord is damaged, it must be replaced by the manufacturer, its service agent or similarly qualified persons in order to avoid accidents.*
- *The appliance shall be installed in accordance with national wiring regulations.*
- *The appliance with electric heater must be separated at least 1 meter from any combustible material.*
- *Contact the authorized service technician for repair or maintenance of this unit.*
- *In order to maintain optimum unit performance, clean filters, coils and fans at least every six months.*
- *Keep in good working conditions, control systems such as thermostats and sensors.*
- *When using this unit keep doors and windows closed in conditioned environments in order to keep hot air out.*



CAUTION

- *Do not drink or use water drained from this unit. Contains pollutants and can cause illness.*



READ THIS MANUAL

Inside you will find many helpful hints on how to use and maintain your dehumidifier properly. Just a little preventive care on your part can save you a great deal of time and money over the life of your dehumidifier. You'll find many answers to common problems in the chart of troubleshooting tips. If you review our chart of Troubleshooting Tips first, you may not need to call for service at all.

When using this dehumidifier in the European countries, the following information must be followed:

DISPOSALS: Do not dispose this product as unsorted municipal waste. Collection of such waste separately for special treatment is necessary.

It is prohibited to dispose of this appliance in domestic household waste. For disposal, there are several possibilities:

- Ⓐ The municipality has established collection systems, where electronic waste can be disposed of charge to the user.
- Ⓑ When buying a new product, the retailer will take back the old product free of charge.
- Ⓒ The manufacture will take back the old appliance for disposal free of charge to the user.
- Ⓓ As old products contain valuable resources, they can be sold to scrap metal dealers.

Wild disposal of waste in forests and landscapes endangers your health when hazardous substances leak into the ground-water and find their way into the food chain.

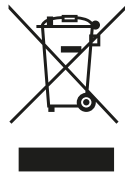



SAFETY PRECAUTIONS

To prevent injury to the user or other people and property damage, the following instructions must be followed. Incorrect operation due to ignoring of instructions may cause harm or damage.

- **The seriousness is classified by the following indications.**



WARNING

This symbol indicates the possibility of death or serious injury.



CAUTIONS

This symbol indicates the possibility of injury or damage to property.

- **Meanings of symbols used in this manual are as shown below.**



Never do this.



Always do this.



WARNING



Do not exceed the rating of the power outlet or connection device.

It may cause Electric shock or fire due to excess heat generation.



Do not modify power cord length or share the outlet with other appliances.

It may cause electric shock or fire due to heat generation.



Disconnect the power if strange sounds, smell or smoke comes out of the unit.

It may cause fire and electric shock.



Do not use the machine near flammable gas or combustibles, such as gasoline, benzene, thinner, etc.

It may cause an explosion or fire.



Do not operate or stop the unit by switching on or off the main power source.

It may cause electric shock or fire due to heat generation.



Do not insert or pull out plug with wet hands.

It may cause electric shock.



You should never try to take apart or repair the unit by yourself.

It may cause failure of machine or electric shock.



Do not drink or use the water drained from the unit.

It contains contaminants and could make you sick.



Do not damage or use an unspecified power cord.

It may cause electric shock or fire.



Do not place the unit near a heat source.

Plastic parts may melt and cause a fire.



Before cleaning, turn off the power and unplug the unit.

It may cause electrical shock or injury.



Do not take the water bucket out during operation.

It may cause the water level sensors activation which may cause electric discharges.



CAUTIONS



Do not use the unit in small spaces.

Lack of ventilation can cause overheating and fire.



Do not put in places where water may splash onto the unit.

Water may enter the unit and degrade the insulation. It may cause an electric shock or fire.



Place the unit on a level, sturdy section of the floor.

If the unit falls over, it may cause water to spill and damage belongings, or cause electrical shock or fire.



Do not cover the intake or exhaust openings with cloths or towels.

A lack of air flow can lead to overheating and fire.



Never insert your finger or other foreign objects into grills or openings. Take special care to warn children of these dangers.

It may cause electric shock or failure of appliance.



Always insert the filters securely. Clean filter once every two weeks.

Operation without filters may cause failure.



Care should be taken when using the unit in a room with the following persons:

Infants, children, elderly people, and people sensitive to humidity.



Do not place heavy object on the power cord and take care so that the cord is not compressed.

There is danger of fire or electric shock.



If water enters the unit, turn the unit off and disconnect the power, contact a qualified service technician.

It may cause failure of appliance or accident.



Do not use in areas where chemicals are handled.

This will cause the units deterioration due to chemicals and solvents dissolved in the air.



Do not climb up or sit on the unit.

You may be injured if you fall or if the unit falls over.



Do not place flower vases or other water containers on top of the unit.

Water may spill inside the unit, causing insulation failure and electrical shock or fire.

ELECTRICAL INFORMATION

- The manufacturer's nameplate is located on the rear panel of the unit and contains electrical and other technical data specific to this unit.
- Be sure the unit is properly grounded. To minimize shock and fire hazards, proper grounding is important.
- The power cord is equipped with a three-prong grounding plug for protection against shock hazards.
- Your unit must be used in a properly grounded wall receptacle.
- If the wall receptacle you intend to use is not adequately grounded or protected by a time delay fuse or circuit breaker, have a qualified electrician install the proper receptacle. Ensure the receptacle is accessible after the unit installation.
- **Do not use extension cords or adapter plugs with this unit.** However, if it is necessary to use an extension cord, use an approved Dehumidifier extension cord only (Available at most local hardware stores).
- To avoid the possibility of personal injury, always disconnect the power supply to the unit, before installing and/or servicing.



NOTE

The control panel of the unit you purchased may be slightly different according to the models.

MODEL A

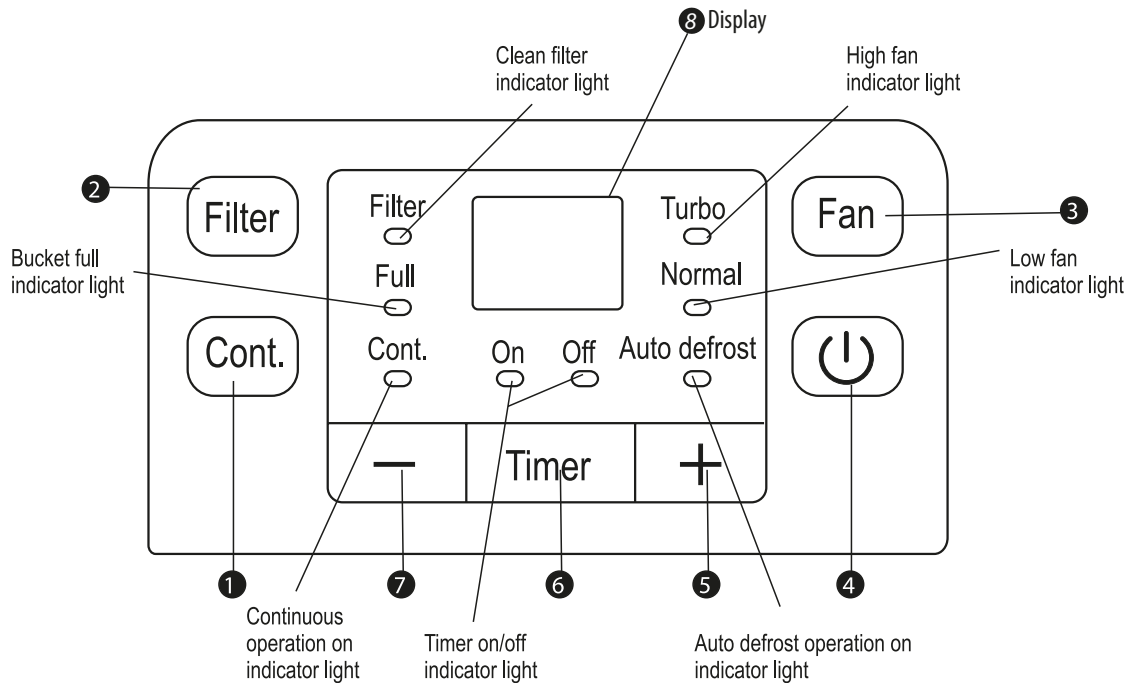

● **Control pads**

When you push the button to change operation modes, the unit will make a beep sound to indicate that it is changing modes.

1 Continue Pad

Press to activate the continuous dehumidifying operation.

2 Filter Pad

The check filter feature is a reminder to clean the Air Filter for more efficient operation. The Filter light (Clean filter light) will illuminate after 250 hours of operation. To reset after cleaning the filter, press the Filter pad and the light will go off.

3 Fan Pad

Control the fan speed. Press to select either High or Normal fan speed. Set the fan control to High for maximum moisture removal. When the humidity has been reduced and quiet operation is preferred, set the fan control to Normal.

4 Power Pad

Press to turn the dehumidifier on and off.

5 7 Teclas Up / Down

● **Humidity Set Control Pads**

The humidity level can be set within a range of 35%RH(Relative Humidity) to 85%RH(Relative Humidity) in 5% increments. For drier air, press the (-) pad and set to a lower percent value(%). For damper air, press the (+) pad and set a higher percent value(%).

● **TIMER Set Control Pads**

Use the (+) (-) pads to set the Auto start and Auto stop time from 0.0 to 24.

6 Timer Pad

Press to initiate the Auto start and Auto stop feature, in conjunction with the ⊕ and ⊖ key pads.

8 Display

Shows the set % humidity level from 35% to 85% or auto start/stop time (0~24) while setting, then shows the actual ($\pm 5\%$ accuracy) room % humidity level in a range of RH (Relative Humidity) to 90%RH (Relative Humidity).

Error Codes and Protection Code:

AS- Humidity sensor error--Unplug the unit and plug it back in. If error repeats, call for service.

ES- Temperature sensor error--Unplug the unit and plug it back in. If error repeats, call for service.

P2- Bucket is full or bucket is not in right position--Empty the bucket and replace it in the right position.

EC- Unit malfunction-Please make sure whether the environment temperature is suitable for the stated temperature in the manual. If not, please operate the unit under the stated temperature. If the environment temperature is suitable for the stated temperature, please call service.

OTHER FEATURES

Bucket Full Light

Glowes when the bucket is ready to be emptied, or when the bucket is removed or not replaced in the proper position.

Auto Shut Off

The dehumidifier shuts off after 30 seconds when the bucket is full, or when the bucket is removed or not replaced in the proper position. When the setting humidity is reached, the unit will be shut off automatically. For some models, the fan motor will continue operating.

Auto Defrost

When frost builds up on the evaporator coils, the compressor will cycle off and the fan will continue to run until the frost disappears.

Wait 3 minutes before resuming operation

After the unit has stopped, it can not be restarted in the first 3 minutes. This is to protect the unit. Operation will automatically start after 3 minutes.

Check filter feature

The system starts to count the time once the fan motor operates. The check filter feature will be activated when the accumulated operation hours reaches 250 or more. The Reset light (Clean filter indicator light) flashes at one time per second, after cleaning and replacing the air filter, press the Filter pad and the Reset light (Clean filter indicator light) goes off.

Auto-Restart

If the unit turns off unexpectedly due to the power cut, it will restart with the previous function setting automatically when the power resumes.

Setting the Timer

- When the unit is on, first press the Timer button, the Timer Off indicator light illuminates. It indicates the Auto Stop program is initiated. Press it again the Time On indicator light illuminates. It indicates the Auto Start is initiated.
- When the unit is off, first press the Timer button, the TIMER ON indicator light illuminates. It indicates the Auto Start program is initiated. Press it again the Time Off indicator light illuminates. It indicates the Auto Stop is initiated.
- Press or hold the UP or DOWN pad to change the Auto time by 0.5 hour increments, up to 10 hours, then at 1 hour increments up to 24 hours. The control will count down the time remaining until start.
- The selected time will register in 5 seconds and the system will automatically revert back to display the previous humidity setting.
- When the Auto start & Auto stop times are set, within the same program sequence, TIMER ON OFF indicator lights illuminate identifying both ON and OFF times are now programmed.
- Turning the unit ON or OFF at any time or adjusting the timer setting to 0.0 will cancel the Auto Start/Stop function.
- When LED display window displays the code of P2, the Auto Start/Stop function will also be cancelled.

IDENTIFICATION OF PARTS

FRONT

- 1 Control panel
- 2 Air intake grille
- 3 Air outlet grille
- 4 Air filter (behind the grille)
- 5 Water bucket
- 6 Handle (both sides)

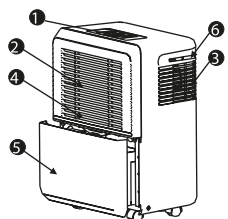

FIG. 2

BACK

- 1 Drain hose outlet
- 2 Caster
- 3 Power Cord and plug
- 4 Band(Used only when storing the unit.)

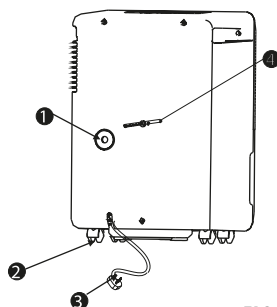

FIG. 3



NOTE

All the pictures in the manual are for explanation purposes only. The actual shape of the unit you purchased may be slightly different, but the operations and functions are the same.

ACCESSORIES

Drain hose(1pc)



adaptor A(1pc)

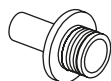

screw(2pc)



POSITIONING THE UNIT

A dehumidifier operating in a basement will have little or no effect in drying an adjacent enclosed storage area, such as a closet, unless there is adequate circulation of air in and out of the area.

- Do not use outdoors.
- This dehumidifier is intended for indoor residential applications only. This dehumidifier should not be used for commercial or industrial applications.
- Place the dehumidifier on a smooth, level floor strong enough to support the unit with a full bucket of water.
- Allow at least 20cm of air space on all sides of the unit for good air circulation.

- Place the unit in an area where the temperature will not fall below 5 °C (41°F). The coils can become covered with frost at temperatures below 5°C(41°F), which may reduce performance.
- Place the unit away from the clothes dryer, heater or radiator.
- Use the unit to prevent moisture damage anywhere books or valuables are stored.
- Use the dehumidifier in a basement to help prevent moisture damage.
- The dehumidifier must be operated in an enclosed area to be most effective.
- Close all doors, windows and other outside openings to the room.

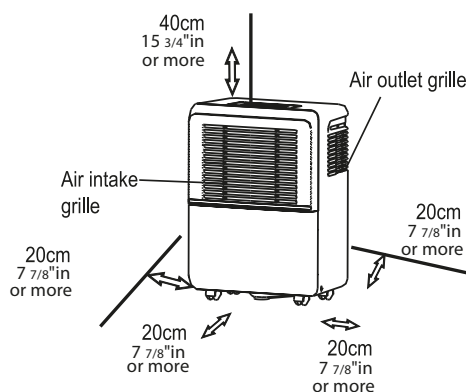

FIG. 4A

Casters (At four points on the bottom of unit)

- Casters can move freely.
- Do not force casters to move over carpet, nor move the unit with water in the bucket. (The unit may tip over and spill water.)

WHEN USING THE UNIT

- When first using the dehumidifier, operate the unit continuously 24 hours.
- This unit is designed to operate with a working environment between 5°C/41°F and 35°C/95°F.
- If the unit has been switched off and needs to be switched on again quickly, allow approximately three minutes for the correct operation to resume.
- Do not connect the dehumidifier to a multiple socket outlet, which is also being used for other electrical appliances.
- Select a suitable location, making sure you have easy access to an electrical outlet.
- Plug the unit into a electrical socket-outlet with ground connection.
- Make sure the Water bucket is correctly fitted otherwise the unit will not operate properly.



NOTE

When the water in the bucket reaches a certain level, please be careful to move the machine to avoid it falling down.

OPERATING THE UNIT

REMOVING THE COLLECTED WATER

There are two ways to remove collected water.

1 Use the bucket

- When the unit is off, if the bucket is full, the unit will beep 8 times and the Full indicator light will flash, the digital display shows P2.
- When the unit is on, if the bucket is full, the compressor turns off and the fan turns off after 30 seconds to dry the water of the condenser, then the unit will beep 8 times and the Full indicator light will flash, the digital display shows P2.
- Slowly pull out the bucket. Grip the left and right handles securely, and carefully pull out straight so water does not spill. Do not put the tank on the floor because the bottom of the bucket is uneven. The bucket will fall and cause the water to spill.
- Throw away the water and replace the bucket. The bucket must be in place and securely seated for the dehumidifier to operate.
- The machine will re-start when the bucket is restored in its correct position.



NOTE

- When you remove the bucket, do not touch any parts inside of the unit. Doing so may damage the product.
- Be sure to push the bucket gently all the way into the unit. Banging the bucket against anything or failing to push it in securely may cause the unit not to operate.
- When you remove the bucket, if there is some water in the unit you must dry it.

1. Pull out the bucket a little.

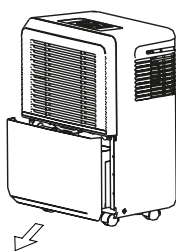

FIG. 5

2. Hold both sides of the bucket with even strength, and pull it out from the unit.

2 Continuous draining

- Water can be automatically emptied into a floor drain by attaching the unit with a water hose (Id≤Ø5/16",not included) with a female threaded end (ID:M=1", not included).
- Install the drain hose onto the adaptor A (See Fig. 7, placed in the bucket).
- Remove the plastic cover from the back drain outlet of the unit and set aside and remove bucket, then insert the drain hose through the drain outlet of the unit and securely press it into the connector on the front of the unit. (See Fig. 9)
- Tighten the adaptor A and the unit by using two screws (Placed in the bucket).
- Install the female threaded end of the water hose into the adaptor A. (See Fig. 10), then lead the water hose to the floor drain or a suitable drainage facility.
- Make sure the hose is secure so there are no leaks.
- Direct the hose toward the drain, making sure that there are no kinks that will stop the water flowing.
- Place the end of the hose into the drain and make sure the end of the hose is leveled or down to let the water flow smoothly.
- Place the bucket back in the unit and make sure that it is positioned correctly.
- Select the desired humidity setting and fan speed on the unit for continuous draining to start.

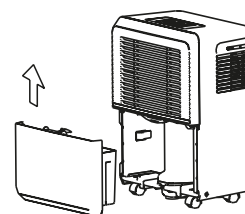

FIG. 6

3. Pour the water out.

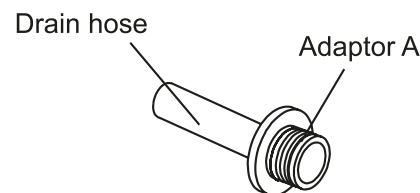

FIG. 7

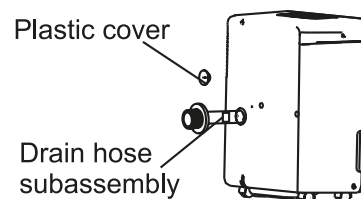

FIG. 8

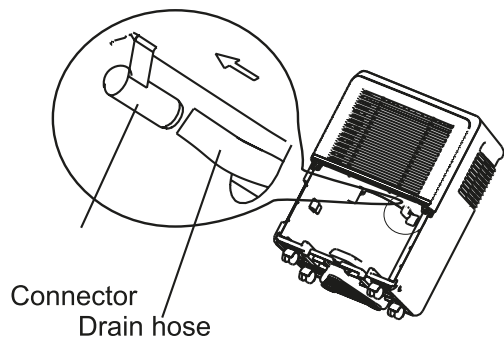

FIG. 9

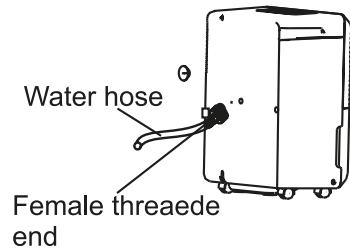

FIG. 10



NOTE

When the continuous drain feature is not being used, remove the drain hose from the outlet.

CARE AND MAINTENANCE

CARE AND CLEANING OF THE DEHUMIDIFIER

Turn the dehumidifier off and remove the plug from the wall outlet before cleaning.

1 Clean the Grille and Case

- Use water and a mild detergent. Do not use bleach or abrasives.
- Do not splash water directly onto the main unit. Doing so may cause an electrical shock, cause the insulation to deteriorate, or cause the unit to rust.
- The air intake and outlet grilles get dirty easily, so use a vacuum or brush to clean.

2 Clean the bucket

- Every few weeks, clean the bucket to prevent growth of mold, mildew and bacteria. Partially fill the bucket with clean water and add a little mild detergent. Mix it around it around in the bucket, empty and rinse.



NOTE

Do not use dishwasher to clean the bucket. Once cleaned, the bucket must be in place and securely seated for the dehumidifier to operate.

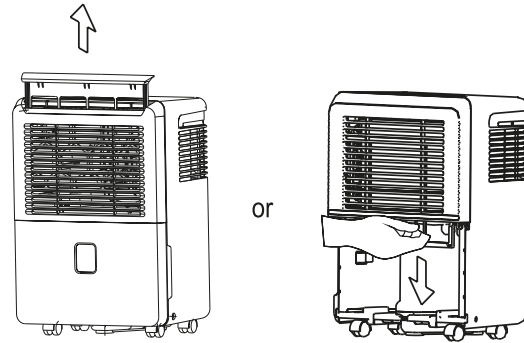

FIG. 11A

FIG. 11B

3 Clean the air filter

- Remove the filter every two weeks based on normal operating conditions.
- Remove the filter from the top of the unit (See Fig.11a), or to remove the filter, remove Bucket then pull filter downwards (See Fig.11b).
- Wash the filter with clean water then dry.
- Re-install the filter, replace Bucket.



NOTE

DO NOT operate the dehumidifier without a filter because dirt and lint will clog it and reduce performance.

4 When not using the unit for long time periods

- After turning off the unit, wait one day before emptying the bucket.
- Clean the main unit, water bucket and air filter.
- Wrap the cord and bundle it with the band (Fig.12).
- Cover the unit with a plastic bag.
- Store the unit upright in a dry, well-ventilated place.

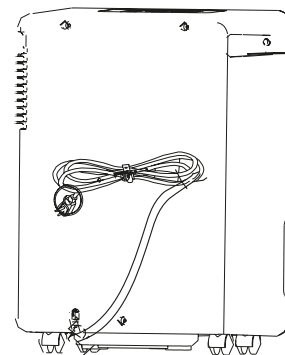

FIG. 12



TROUBLESHOOTING TIPS

Before calling for service, review the chart below first.

Problem	What to check
Unit does not start	<ul style="list-style-type: none">• Make sure the dehumidifier's plug is pushed completely into the outlet.• Check the house fuse/circuit breaker box.• Dehumidifier has reached its preset level or bucket is full.• Water bucket is not in the proper position.
Dehumidifier does not dry the air as it should	<ul style="list-style-type: none">• Did not allow enough time to remove the moisture.• Make sure there are no curtains, blinds or furniture blocking the front or back of the dehumidifier.• The humidity control may not be set low enough.• Check that all doors, windows and other openings are securely closed.• Room temperature is too low, below 5°C (41°F).• There is a kerosene heater or something giving off water vapor in the room.
The unit makes a loud noise when operating	<ul style="list-style-type: none">• The air filter is clogged.• The unit is tilted instead of upright as it should be.• The floor surface is not level.
Frost appears on the coils	<ul style="list-style-type: none">• This is normal. The dehumidifier has Auto defrost feature.
Water on floor	<ul style="list-style-type: none">• Hose to connector or hose connection may be loose.• Intend to use the bucket to collect water, but the back drain plug is removed.
ES, AS, P2and EC appear in the display	<ul style="list-style-type: none">• These are error codes and protection code. See the CONTROL PADS ON THE DEHUMIDIFIER section.

